

ELITESTRUT SPECIFICATIONS

ELITESTRUT channels are known for their durability, accountability and reusability. Each engineered ELITESTRUT channel is manufactured from cold rolled high quality carbon steel of varying gage and depths. Our products have a cross-section of accurate dimensions with a minimum tolerance limit from these technical processes.

GAGE	MATERIAL	ASTM STAND RED
12 &14	PRE-GALVANIZED	A-653
12 &14	PLAIN - STEEL	A-101 1SS
12 &14	STA INLESS - STEEL	A-240
12 &14	HOT DIP GALVANIZED	A-123 , A-153

LENGTH INFORMATION

ELITESTRUT channels are available in 10 and 20 foot sizes with the tolerance of about 1/8". Customized lengths will also be produced upon special request.

WELDING

Spot welding technique is being used to combine two or more ELITESTRUT channels to fabricate various combinations. Evenly spaced spot welds are placed on centers along the length of the multiple channel sections.

SURFACE FINISH

The performance of ELITESTRUT channels have been improvised by pre-galvanizing and superior resistance coating. Pre-galvanized and Green Powder coated channels are available in stock. (Please refer to the technical section for further details.)

ELITESTRUT BEAM AND COLUMN LOADING APPLICATION

Calculations of load, the support conditions, cross-sectional shape, material and nature of loading applied to beam and column strut applications with and without hole are taken from '*Machinery's Handbook, 27th edition*'.

SURFACE FINISH

PRE-GALVANIZED: Prior to fabrication mill galvanized coating is produced by passing steel sheets continuously through the molten Zinc in accordance with ASTM A-653. The steel is then recoiled and processed to give various configurations and sizes of ELITESTRUT. Thickness of Zn coating conforms to ASTM G90 which will be 0.45oz./sq.ft of surface area. Pre-galvanized steel should be able to stand with severe corrosive indoor as well as outdoor applications. Zinc near uncoated metal surface (slitting and fabrication) provides sufficient protection to exposed areas.

HOT-DIP GALVANIZED: Finished UNIQUESTRUT channels are completely immersed into the bath of molten Zinc to completely cover all exposed area with the thickness of 1.5oz./sq.ft of surface area in accordance with ASTM A-123. This coating will ensure the channels from prolonged outdoor corrosive atmosphere.

GREEN POWDER COATED: Polyurethane powder coating is applied electrostatically after the fabrication of ELITESTRUT. Prior to coating the channel is pre treated and properly cleaned and end through the baking process establishing a bond in between. 1.5 mil thickness of coating provides good resistance to wear and tear.

PLAIN STEEL: As the name designate, ELITESTRUT plain steel channel does not have any kind of coating. It does retain an oily surface applied prior to the rolling process and offers no protection from corrosive conditions.

ZINC COATING: From the graph you can very well expect that the life of ELITESTRUT almost becomes twice as the thickness of Zn coating becomes double. Excellent engineering and quality services gives ELITESTRUT a cutting edge over the other manufacturers.

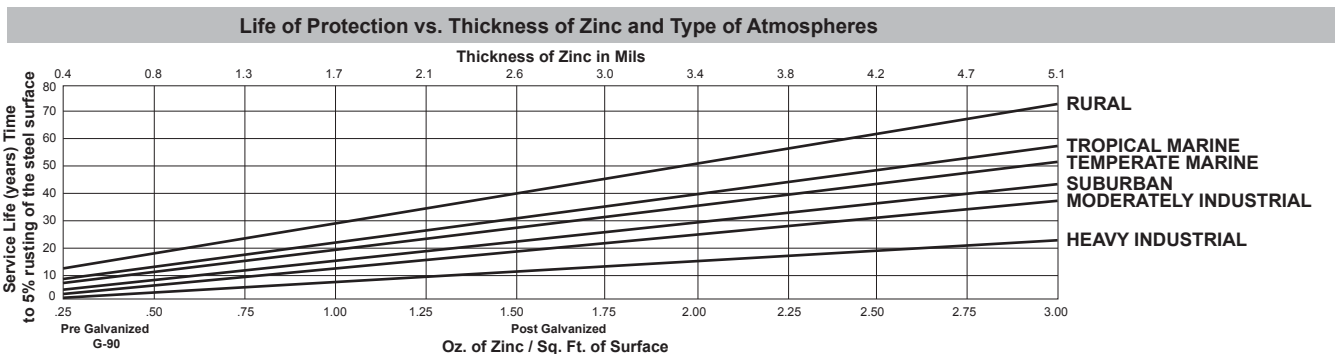

DESIGN BASICS

BEAMS:

ELiTESTRUT channels are capable of withstanding load primarily by resisting the bending. The bending force induced into ELiTESTRUT channels as result of external (perpendicular) loads, own weight and external reaction to these loads. The load carrying ability of ELiTESTRUT channel beam depends upon various factors such as:

- 1). Nature of Loading.
- 2). Amount of Load applied.
- 3). Support conditions and the stiffness of the beam.

STRESSES AND DEFLECTION:

The following equations for load distribution are referenced from 'Machinery's Handbook, 27th edition.' Extensive list of formulas for stresses and deflection in beams is given below:

Types of Loading:

A sequence point loads can act as uniform loading. There can be different combinations in which point load and uniform load can act together.

UNIFORM LOAD

Evenly distributed load spread over the entire length of the beam from support to support is 'Uniform Load'.

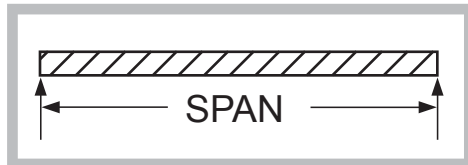

POINT LOAD

Point load is the concentrated load that is applied perpendicularly onto a very small length of the beam.

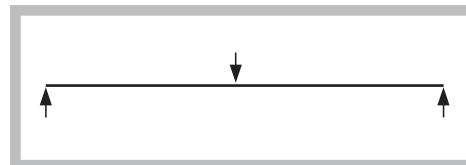

Types of Support Conditions:

A sequence point loads can act as uniform loading. There can be different combinations in which point load and uniform load can act together.

SIMPLE BEAM

A simple beam is supported at both of its ends, restricts the motion in horizontal and vertical direction, but allows it to bend into an estimated deflected profile. Majority of ELiTESTRUT channels connections are generated in proximity with simple beams. Loading charts and tables presented in this catalog are based on detailed analysis of simple beams.

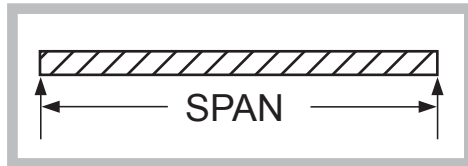

FIXED BEAM

Fixed beam is welded in, general, at both of its ends and even restricts its natural deflection under normal loading conditions. Greater stiffness provided because of its rigid ends gives an increased load capacity as compared with equivalent simple beam.

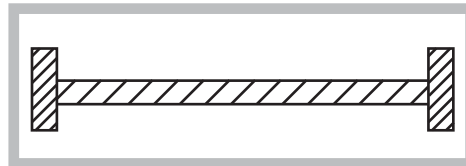

CONTINUOUS BEAM

Continuous beam is supported at more than two supports. These beams acts as simple beams on the outside spans and as a fixed beam approximately in a manner on the inside spans.

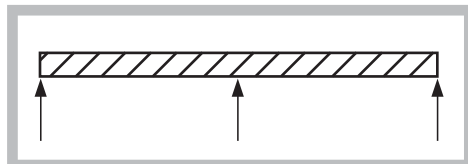

CANTILEVER BEAM

Cantilever beam is a fixed end beam supported at one end while the other end is unsupported. ELiTESTRUT brackets are the good examples for cantilever beam loading.

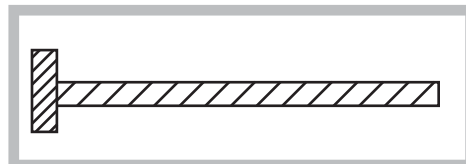

DEFLECTION:

Under normal loading conditions, all beams will deflect. The extent of deflection depends upon the following reasons:

- 1). Total amount of load (beam load and applied load.)
- 2). Nature of load distribution.
- 3). Manner by which beam is supported.
- 4). Beam's cross-sectional stiffness.
- 5). Beam's material stiffness.

'Moment of Inertia', "I" defines the stiffness of the structure. For greater value of I, the smaller is its deflection. Altering the value of I for both major and minor axis can greatly affect its structural stiffness.

'Modulus of elasticity', "E" defines the stiffness of the material for beams. Similarly for greater value of E, the smaller is its deflection. Strength of a material depends upon various other factors and E is one of them, so necessarily the strength must not be confused with E.

For most of the cases, maximum deflection determines the loading capacity of the ELITESTRUT channels. Detailed analysis of the data is provided in this catalog.

BENDING MOMENT:

Additional Load bearing capacity of the beam to support its own weight, anticipated loads and variations in applied load is the key factor in designing. This extended capacity is called 'Factor of Safety' and governed by various design codes and standards. Most common technique to determine the beam's capacity is allowable stress method in which the beams maximum allowable stress is calculated in pound per sq. inch (psi). The data for the maximum allowable uniform loads presented in this catalog conforms to AISI "Specification for the Design of Cold-Formed Steel Structural Members". We have used the common methodology of dividing the bending moment by the section modulus 'S' to get the value of maximum allowable stress. It is to be noted that there may be a situation where the deflection or sagging will be appreciable and can be visualized, but this should not be confused with wrong designed beam installation.

COLUMN LOADING:

ELITESTRUT channels are designed to bear the compressive loads (i.e. when the load acts parallel to the length of the channels). Generally, all structural members that are subjected to vertical compression loads, such as diagonal brace, considered as Column.

Buckling is a failure mode characterized by a sudden failure of a structural member subjected to high compressive stresses, where the actual compressive stress at the point of failure is less than the ultimate compressive stresses that the material is capable of withstanding. Allowable column loading depends upon various factors such as:

- 1). **Total length of Column:** Length of the column is considered as the distance between the two braces.
- 2). **Nature of Loading:**

a). **Concentric Loading:** In this type of loading, the load is applied at the cross-sectional center of gravity of the column such as, load that rests on the top of a column.

b). **Eccentric Loading:** Loading that has not been applied as concentric is considered as eccentric loading. The eccentricity plays a vital role in load carrying capacity of a column. ELITE FIXINGS bolted to the strut channel slot will transmit the eccentricity. Most of the data that is being produced is concentric loading.

- 3). **Support Conditions:** End support conditions for columns are mathematically represented by their 'K' value.

a). **Fixed Top – Fixed Bottom:**

Both the ends are restrained against rotation and any other lateral movements.



$K = 0.65$

b). **Pinned Top – Fixed Bottom:**

Top end is restricted to the translational movements but is allowed to deform (rotate). The bottom end is restrained against both rotational and translational movements.



$K = 0.80$

c). **Pinned Top – Pinned Bottom:**

Both of the ends are restrained to their translational movements but are allowed to rotate.



$K = 1.00$

- 4). **Cross-Sectional Shape:** Radius of gyration 'r' is used to describe the distribution of cross sectional area in a column around its centroidal axis. Column with larger 'r' value are stiffer than those with smaller values.







BOLT TORQUE:

In order to ensure proper bolt tension between ELITESTRUT and framing components, specific torque values are recommended. It is important to note that in a manner, there is direct relation between torque and bolt tension. Greater tension in the bolt might lead to its early failure and too loose will prevent it from its full load capacity. Factors affecting this relationship are presence or lack of lubricant and metal finish. Too much lubrication between the threads will cause the over-tightening of the bolts for the same amount of torque. These values are developed for properly using a calibrated torque wrench with a clean dry ELITESTRUT fitting, bolt and nut.

BOLT TORQUE						
BOLT SIZE	1/4" -20	5/16" -18	3/8" -16	1/2" -13	5/8" -11	3/4" -10
Rec. Torque Ft/Lbs (N.m)	6 (8)	11 (15)	19 (26)	50 (68)	100 (136)	125 (170)
Max Torque Ft/Lbs (N.m)	7 (9)	15 (20)	25 (34)	70 (95)	125 (170)	135 (183)

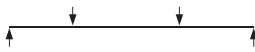
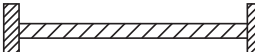
LOADING CHART

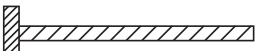
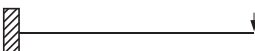
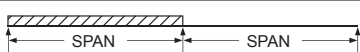
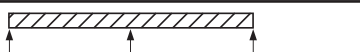
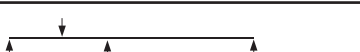
The following load chart table gives an extensive list of formulas for stresses, deflections and derived conversion factors in beams and shafts. These factors must be multiplied by the load ratings in order to get the maximum recommended load in that application for the type of ELITESTRUT is being used.

TYPE OF LOADING APPLICATION	LOAD FACTOR	DEFLECTION FACTOR
Simple beam with a uniformly applied load and supported at each end. 	1.00	1.00
Simple beam with concentrated load at center. 	0.50	1.60
Simple beam with 2 equal concentrated load at 1/4 of length from each end. 	0.50	1.60
Uniform Load, Beam Fixed at both ends. 	1.50	0.20
Fixed Beam, Concentrated Load at center. 	1.00	0.40
Cantilever Beam with uniform load distribution. 	0.25	2.40
Cantilever Beam with load at end. 	0.12	3.20
Continuous beam over two equal span with uniform load on one. 	1.30	0.92
Continuous beam over two equal span with uniform load. 	1.30	0.92
Continuous beam over 2 equal span with a concentrated load at center of each span. 	0.62	0.71
Continuous beam over 2 equal span with a concentrated load at center of one span. 	0.67	0.48

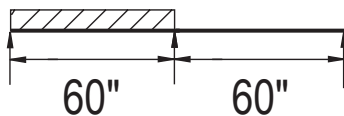

EXAMPLE I:

Compute the load and deflection of A12 beam continuous over one support and loaded uniformly on one span.

SOLUTION:

Please refer to the Beam Loading Table A12 for 60 inches span the maximum allowable uniform load is 680 and the deflection is 0.35inches.

For this case:

$$\text{Load} = 680 \times 1.30 = 884 \text{ lbs.}$$

$$\text{Deflection} = 0.35 \times 0.92 = 0.32 \text{ inches.}$$

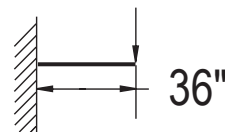

EXAMPLE II

Compute the load and deflection of A14 cantilever beam with a concentrated load at one end.

SOLUTION:

Please refer to the Beam Loading Table A14 for 36 inches span the maximum allowable uniform load is 900 and the deflection is 0.13inches.

For Cantilever Loading case:

$$\text{Load} = 900 \times 0.12 = 108 \text{ lbs.}$$

$$\text{Deflection} = 0.13 \times 3.20 = 0.416 \text{ inches.}$$

BEAM SUPPORT CONDITIONS

Cantilever Beams

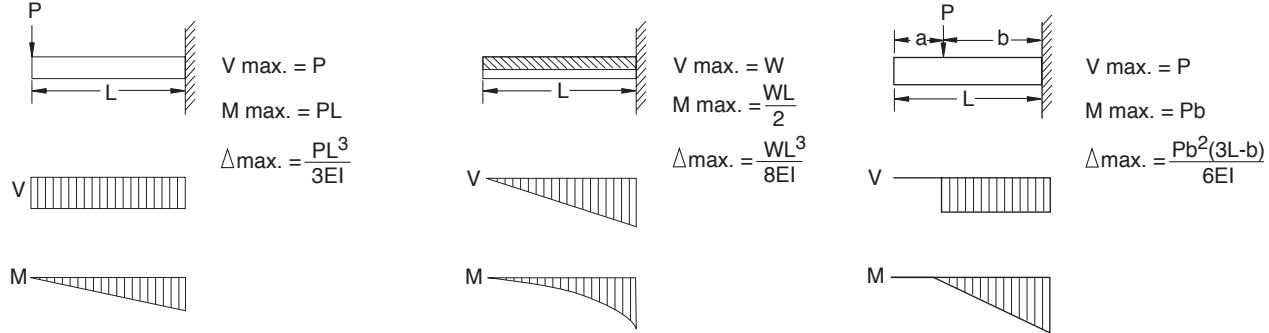

Simple Beams

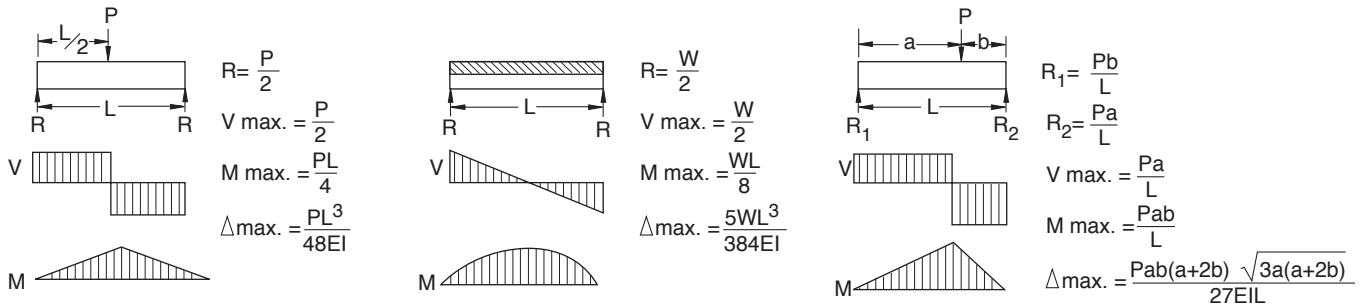

Beams Fixed At One End & Supported At The Other

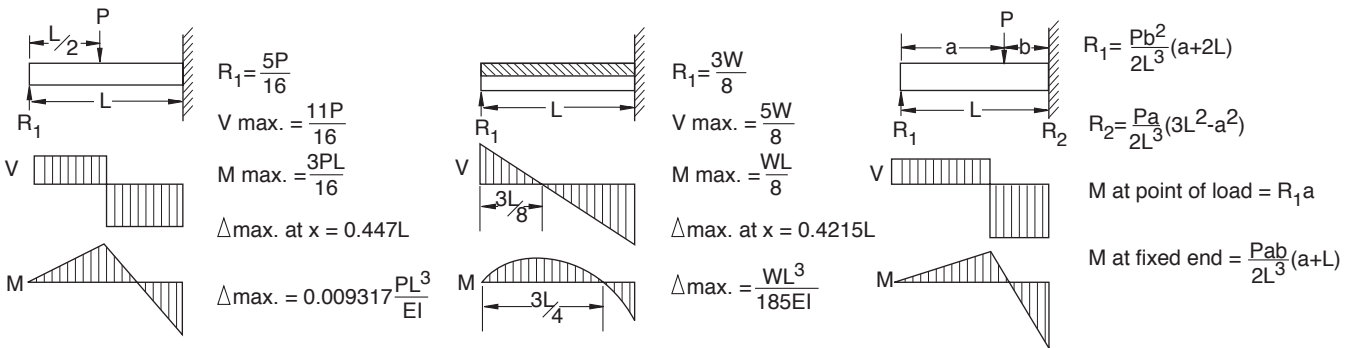

Beams Fixed At Both Ends

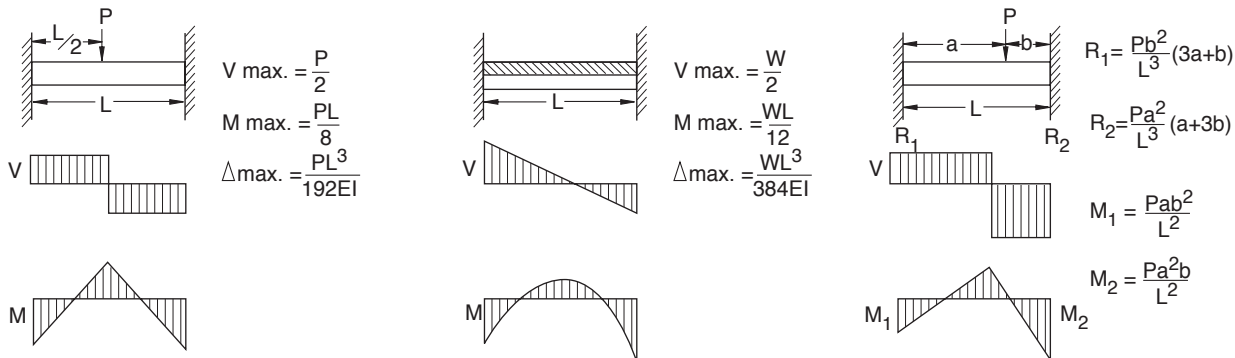

R – Reaction
 M – Moment
 P – Concentrated Load

W – Total Uniform Load
 V – Shear
 L – Length

Δ – Deflection
 E – Modulus of Elasticity
 I – Moment of Inertia

STRUTS A12 (1 5/8" x 1 5/8") BEAM LOADING ES A12

BEAM SPAN (IN.)	MAX. ALLOWABLE UNIFORM LOAD (lbs) at 25000 psi.	Deflection at 25,000 psi (in.)	UNIFORM LOADING (lbs) AT DEFLECTION = SPAN /240
24	1692	0.06	1692
36	1130	0.13	1130
48	846	0.223	757
60	680	0.35	480
72	564	0.503	337
84	480	0.68	250
96	420	0.89	190
108	376	1.131	150
120	340	1.4	120
144	280	2	80
168	240	2.72	60
192	210	3.55	50
216	190	4.58	40
240	163	5.5	30

COLUMN LOADING ES A12

COLUMN UNBRACED HEIGHT (IN.)	MAX. LOAD (lbs) of COLUMN LOADED at C.G.	COLUMN EFFECTIVE LENGTH FACTOR			
		K = 0.65	K = 0.80	K = 1.0	K = 1.2
24	3590	10861	9890	8770	7740
36	3190	8994	7740	6390	5310
48	2770	7250	6010	4690	3800
60	2380	5910	4690	3630	2960
72	2080	4840	3800	2960	2400
84	1860	4040	3200	2480	1980
96	1670	3480	2750	2110	1660
108	1510	3050	2400	1810	**
120	1380	2700	2110	**	**
144	1150	2180	1660	**	**

SECTIONAL PROPERTIES

Channel Part No.	Weight lbs/ft	Area of Section (in ³)	AXIS X - X			AXIS Y - Y		
			I(in ⁴)	S(in ³)	r(in.)	I(in ⁴)	S(in ³)	r(in.)
A12	1.94	0.544	0.18	0.195	0.575	0.233	0.287	0.655
A12BTB	3.88	1.088	0.896	0.57	0.908	0.466	0.574	0.655

I = Moment of Inertia

S = Section Modulus

r = Radius of Gyration.

STRUT ES A12 BTB (1 5/8" x 3 1/4") BEAM LOADING ES A12 BTB

BEAM SPAN (IN.)	MAX. ALLOWABLE UNIFORM LOAD (lbs) at 25000 psi.	Deflection at 25,000 psi (in.)	UNIFORM LOADING (lbs) AT DEFLECTION = SPAN /240
24	2610*	0.032	2610*
36	2610*	0.072	2610*
48	2610*	0.129	2610*
60	1899*	0.202	1899*
72	1582*	0.291	1582*
84	1356	0.396	1199
96	1187	0.517	917
108	1055	0.655	725
120	949	0.808	587
144	800	1.14	420
168	680	1.53	310
192	600	2.02	240
216	530	2.54	190
240	480	3.16	150

COLUMN LOADING ES A12 BTB

COLUMN LOADING UNBRACED HEIGHT (IN.)	MAX. LOAD (lbs) of COLUMN LOADED at C.G.	COLUMN EFFECTIVE LENGTH FACTOR			
		K = 0.65	K = 0.80	K = 1.0	K = 1.2
24	6430	24280	23610	22700	21820
36	6290	22810	21820	20650	19670
48	6160	21410	20300	18670	16160
60	6000	20210	18670	15520	12390
72	5620	18970	16160	12390	8950
84	5170	16950	13630	9470	6580
96	4690	14890	11190	7250	5040
108	4170	12850	8950	5730	3980
120	3690	10900	7250	4640	**
144	2930	7630	5040	**	**

NOTES:

* Loads are limited by spot weld shear.

** $KL/r > 200$

1). Above loads include the weight of the member. To get the allowable load capacity of the beam member weight must be deducted.

2). Loads are listed for unbraced height and modulus of elasticity is 29,000,000 psi.

STRUTS A14 (1 5/8" x 1 5/8") BEAM LOADING ES A14

BEAM SPAN (IN.)	MAX. ALLOWABLE UNIFORM LOAD (lbs) at 25000 psi.	Deflection at 25,000 psi (In.)	UNIFORM LOADING (lbs) AT DEFLECTION = SPAN /240
24	1316	0.056	1316
36	900	0.13	900
48	658	0.224	587
60	526	0.35	376
72	439	0.504	261
84	376	0.687	192
96	329	0.897	147
108	292	1.135	116
120	263	1.4	94
144	230	2.09	70
168	190	2.75	50
192	170	3.67	40
216	150	4.61	30
240	132	5.605	23

COLUMN LOADING ES A14

COLUMN LOADING UNBRACED HEIGHT (IN.)	MAX. LOAD (lbs) of COLUMN LOADED at C.G.	COLUMN EFFECTIVE LENGTH FACTOR			
		K = 0.65	K = 0.80	K = 1.0	K = 1.2
24	2800	8040	7330	6360	5430
36	2410	6480	5430	4190	3210
48	1940	4990	3830	2760	2160
60	1550	3740	2760	2050	1640
72	1290	2860	2160	1640	1320
84	1100	2310	1780	1370	1110
96	950	1950	1500	1180	950
108	840	1690	1320	1030	**
120	760	1490	1180	**	**
144	630	1210	950	**	**

SECTIONAL PROPERTIES

Channel Part No.	Weight lbs/ft	Area of Section (in ³)	AXIS X - X			AXIS Y - Y		
			I(in ⁴)	S(in ³)	r(in.)	I(in ⁴)	S(in ³)	r(in.)
A14	1.45	0.407	0.143	0.158	0.593	0.179	0.221	0.664
A14BTB	2.9	0.814	0.706	0.445	0.931	0.359	0.441	0.664

I = Moment of Inertia

S = Section Modulus

r = Radius of Gyration.

STRUT ES A14 BTB (1 5/8" x 3 1/4") BEAM LOADING ES A14 BTB

BEAM SPAN (IN.)	MAX. ALLOWABLE UNIFORM LOAD (lbs) at 25000 psi.	Deflection at 25,000 psi (In.)	UNIFORM LOADING (lbs) AT DEFLECTION = SPAN /240
24	1750*	0.032	1750*
36	1750*	0.072	1750*
48	1750*	0.128	1750*
60	1482	0.2	1482*
72	1235	0.288	1235*
84	1058	0.392	944
96	926	0.512	723
108	823	0.649	571
120	741	0.801	463
144	630	1.13	440
168	540	1.54	330
192	470	2	250
216	420	2.55	200
240	370	3.203	116

COLUMN LOADING ES A14 BTB

COLUMN LOADING UNBRACED HEIGHT (IN.)	MAX. LOAD (lbs) of COLUMN LOADED at C.G.	COLUMN EFFECTIVE LENGTH FACTOR			
		K = 0.65	K = 0.80	K = 1.0	K = 1.2
24	5010	18250	17700	16880	16030
36	4860	16990	16030	14770	13620
48	4700	15610	14380	12930	11750
60	4480	14280	12930	11490	9290
72	4210	13100	11750	9290	6700
84	3880	12090	10220	7090	4930
96	3480	11170	8390	5430	3770
108	3060	9640	6700	4290	2980
120	2680	8170	5430	3480	**
144	2090	5710	3770	**	**

NOTES:

* Loads are limited by spot weld shear.

** $KL/r > 200$

1). Above loads include the weight of the member. To get the allowable load capacity of the beam member weight must be deducted.

2). Loads are listed for unbraced height and modulus of elasticity is 29,000,000 psi.

STRUTS C12 (1 5/8" x 13/16") BEAM LOADING ES C12

BEAM SPAN (IN.)	MAX. ALLOWABLE UNIFORM LOAD (lbs) at 25000 psi.	Deflection at 25,000 psi (In.)	UNIFORM LOADING (lbs) AT DEFLECTION = SPAN /240
24	513	0.105	490
36	342	0.235	218
48	256	0.419	122
60	205	0.654	78
72	171	0.941	54
84	146	1.282	40
96	128	1.674	31
108	114	2.119	24
120	103	2.616	20
144	90	3.84	NA
168	80	5.43	NA
192	70	6.09	NA
240	51	6.689	5

COLUMN LOADING ES C12

COLUMN LOADING UNBRACED HEIGHT (IN.)	MAX. LOAD (lbs) of COLUMN LOADED at C.G.	COLUMN EFFECTIVE LENGTH FACTOR			
		K = 0.65	K = 0.80	K = 1.0	K = 1.2
24	2250	7480	6800	5820	4810
36	1980	5950	4810	3380	2350
48	1580	4310	2970	1900	**
60	1210	2880	1900	**	**
72	**	2000	**	**	**
84	**	**	**	**	**
96	**	**	**	**	**
108	**	**	**	**	**
120	**	**	**	**	**
144	**	**	**	**	**

SECTIONAL PROPERTIES

Channel Part No.	Weight lbs/ft	Area of Section(in ³)	AXIS X - X			AXIS Y - Y		
			I(in ⁴)	S(in ³)	r(in.)	I(in ⁴)	S(in ³)	r(in.)
C12	1.374	0.374	0.03	0.062	0.283	0.135	0.166	0.6
C12 BTB	2.7	0.748	0.14	0.184	0.432	0.27	0.332	0.6

I = Moment of Inertia

S = Section Modulus

r = Radius of Gyration.

STRUT ES C12 BTB (1 5/8" x 1 5/8") BEAM LOADING ES C12 BTB

BEAM SPAN (IN.)	MAX. ALLOWABLE UNIFORM LOAD (lbs) at 25000 psi.	Deflection at 25,000 psi (in.)	UNIFORM LOADING (lbs) AT DEFLECTION = SPAN /240
24	1270 *	0.067	1270 *
36	1020	0.15	1017
48	765	0.267	572
60	612	0.418	366
72	510	0.602	254
84	437	0.819	187
96	382	1.07	143
108	340	1.354	113
120	306	1.672	91
144	250	2.25	70
168	220	3.14	50
192	190	4.05	NA
216	170	5.16	NA
240	153	6.689	NA

COLUMN LOADING ES C12 BTB

COLUMN LOADING UNBRACED HEIGHT (IN.)	MAX. LOAD (lbs) of COLUMN LOADED at C.G.	COLUMN EFFECTIVE LENGTH FACTOR			
		K = 0.65	K = 0.80	K = 1.0	K = 1.2
24	4140	16490	15980	14970	13810
36	3980	15100	13810	11910	9940
48	3730	13190	11260	8650	6270
60	3390	11090	8650	5780	4010
72	2950	8970	6270	4010	2790
84	2510	6980	4610	2950	**
96	2130	5340	3530	**	**
108	1820	4220	2790	**	**
120	**	3420	**	**	**
144	**	**	**	**	**

NOTES:

* Loads are limited by spot weld shear.

** $KL/r > 200$

NA = Not Allowable.

1). Above loads include the weight of the member. To get the allowable load capacity of the beam member weight must be deducted.

2). Loads are listed for unbraced height and modulus of elasticity is 29,000,000 psi.

STRUTS C14 (1 5/8" x 13/16") BEAM LOADING ES C14

BEAM SPAN (IN.)	MAX. ALLOWABLE UNIFORM LOAD (lbs) at 25000 psi.	Deflection at 25,000 psi (in.)	UNIFORM LOADING (lbs) AT DEFLECTION = SPAN /240
24	444	0.106	416
36	296	0.24	185
48	222	0.427	104
60	177	0.667	66
72	148	0.96	46
84	127	1.037	34
96	111	1.707	26
108	99	2.16	21
120	89	2.668	17
144	80	4.09	NA
168	60	4.88	NA
192	60	7.28	NA
216	50	8.64	NA
240	50	11.85	NA

COLUMN LOADING ES C14

COLUMN LOADING UNBRACED HEIGHT (IN.)	MAX. LOAD (lbs) of COLUMN LOADED at C.G.	COLUMN EFFECTIVE LENGTH FACTOR			
		K = 0.65	K = 0.80	K = 1.0	K = 1.2
24	1840	5610	5210	4570	3850
36	1640	4660	3850	2800	1960
48	1310	3490	2480	1590	1100
60	1000	2400	1590	**	**
72	770	1670	1100	**	**
84	**	**	**	**	**
96	**	**	**	**	**
108	**	**	**	**	**
120	**	**	**	**	**
144	**	**	**	**	**

SECTIONAL PROPERTIES

Channel Part No.	Weight lbs/ft	Area of Section (in ³)	AXIS X - X			AXIS Y - Y		
			I (in ⁴)	S (in ³)	r (in.)	I (in ⁴)	S (in ³)	r (in.)
C14	1.03	0.286	0.025	0.053	0.298	0.106	0.131	0.61
C14BTB	2.06	0.571	0.115	0.149	0.449	0.213	0.262	0.61

I = Moment of Inertia

S = Section Modulus

r = Radius of Gyration.

STRUTS C14 BTB (1 5/8" x 1 5/8") BEAM LOADING ES C14 BTB

BEAM SPAN (IN.)	MAX. ALLOWABLE UNIFORM LOAD (lbs) at 25000 psi.	Deflection at 25,000 psi (in.)	UNIFORM LOADING (lbs) AT DEFLECTION = SPAN /240
24	1090*	0.06	1090*
36	800	0.14	480
48	600	0.25	310
60	480	0.39	210
72	400	0.57	160
84	340	0.76	120
96	300	1	90
108	270	1.29	80
120	240	1.57	50
144	200	2.26	40
168	170	3.05	NA
192	150	4.02	NA
216	130	4.96	NA
240	120	6.28	NA

COLUMN LOADING ES C14 BTB

COLUMN LOADING UNBRACED HEIGHT (IN.)	MAX. LOAD (lbs) of COLUMN LOADED at C.G.	COLUMN EFFECTIVE LENGTH FACTOR			
		K = 0.65	K = 0.80	K = 1.0	K = 1.2
24	3240	12370	11950	11370	10540
36	3120	11470	10540	9160	7720
48	2940	10090	8680	6770	4980
60	2680	8560	6770	4590	3190
72	2310	7010	4980	3190	2220
84	1950	5530	3660	2340	**
96	1650	4250	2800	**	**
108	1410	3360	2220	**	**
120	**	**	**	**	**
144	**	**	**	**	**

NOTES:

* Loads are limited by spot weld shear.

** $KL/r > 200$

NA = Not Allowable.

1). Above loads include the weight of the member. To get the allowable load capacity of the beam member weight must be deducted.

2). Loads are listed for unbraced height and modulus of elasticity is 29,000,000 psi.

STRUTS E12 (1 5/8" x 3 1/4") BEAM LOADING ES E12

BEAM SPAN (IN.)	MAX. ALLOWABLE UNIFORM LOAD (lbs) at 25000 psi.	Deflection at 25,000 psi (in.)	UNIFORM LOADING (lbs) AT DEFLECTION = SPAN /240
24	5077 *	0.029	5077 *
36	3385 *	0.065	3385 *
48	2539 *	0.115	2539 *
60	2031 *	0.18	2031 *
72	1692 *	0.26	1692 *
84	1451	0.354	1436
96	1269	0.462	1099
108	1128	0.322	869
120	1015	0.722	703
144	880	1.06	500
168	750	1.43	370
192	660	1.88	280
216	580	2.35	220
240	530	2.95	180

COLUMN LOADING ES E12

COLUMN LOADING UNBRACED HEIGHT (IN.)	MAX. LOAD (lbs) of COLUMN LOADED at C.G.	COLUMN EFFECTIVE LENGTH FACTOR			
		K = 0.65	K = 0.80	K = 1.0	K = 1.2
24	5650	16870	15180	12850	10600
36	4690	13140	10600	7650	5660
48	3560	9550	6860	4790	3660
60	2730	6680	4790	3450	2710
72	2160	4980	3660	2710	2170
84	1760	3950	2960	2240	1820
96	1500	3270	2500	1930	1580
108	1310	2800	2170	1690	1390
120	1170	2450	1930	1510	**
144	980	1980	1580	**	**
168	850	1670	1340	**	**

SECTIONAL PROPERTIES

Channel Part No.	Weight lbs/ft	Area of Section (in ³)	AXIS X - X			AXIS Y - Y		
			I (in ⁴)	S (in ³)	r (in.)	I (in ⁴)	S (in ³)	r (in.)
E12	3.13	0.844	1.073	0.609	1.102	0.429	0.529	0.697
E12BTB	6.26	1.768	6.064	1.896	1.852	0.859	1.057	0.697

I = Moment of Inertia

S = Section Modulus

r = Radius of Gyration.

STRUT ES E12 BTB (1 5/8" x 6 1/2") BEAM LOADING ES E12 BTB

BEAM SPAN (IN.)	MAX. ALLOWABLE UNIFORM LOAD (lbs) at 25000 psi.	Deflection at 25,000 psi (in.)	UNIFORM LOADING (lbs) AT DEFLECTION = SPAN /240
24	5130*	0.016	5130*
36	5130*	0.036	5130*
48	5130*	0.064	5130*
60	5130*	0.099	5130*
72	5130*	0.143	5130*
84	4515	0.195	4515
96	3950	0.254	3950
108	3512	0.322	3512
120	3160	0.398	3160
144	2680	0.57	2680
168	2290	0.77	2080
192	2010	1.01	1590
216	1780	1.27	1260
240	1580	1.58	994

COLUMN LOADING ES E12 BTB

COLUMN LOADING UNBRACED HEIGHT (IN.)	MAX. LOAD (lbs) of COLUMN LOADED at C.G.	COLUMN EFFECTIVE LENGTH FACTOR			
		K = 0.65	K = 0.80	K = 1.0	K = 1.2
24	10670	39230	38030	36210	34240
36	10350	36450	34240	31200	28260
48	9940	33220	30200	26430	23190
60	9290	29950	26430	22470	19380
72	8560	26880	23190	19380	16450
84	7860	24140	20520	17040	12090
96	7220	21790	18370	13330	9250
108	6600	19790	16450	10530	7310
120	5760	18130	13330	8530	**
144	4390	14020	9250	**	**
168	3420	10300	6800	**	**

NOTES:

* Loads are limited by spot weld shear.

** $KL/r > 200$

NA = Not Allowable.

1). Above loads include the weight of the member. To get the allowable load capacity of the beam member weight must be deducted.

2). Loads are listed for unbraced height and modulus of elasticity is 29,000,000 psi.